

ASME B16.34 INDUSTRIAL BALL VALVES

Apollo Valves, manufactured by Conbraco Industries, Inc., are Designed, Cast, Machined, Assembled, and Tested at our state-of-the-art facilities located in the USA. Vertical manufacturing operations assure better quality control, better cost control, and the shortest delivery lead times possible.

American Made Quality since 1928

Heavy Duty ASME B16.34 Class 150, 300 & 600 designs

Single-Source Responsibility

Broad Range of Materials

High Flow Capacity

Full range of valve options

Models available for specific services,
such as chlorine, oxygen, NACE

Complete range of actuators and accessories

NEW

New Class 600 Full Port Flange Valves

Five Year Warranty

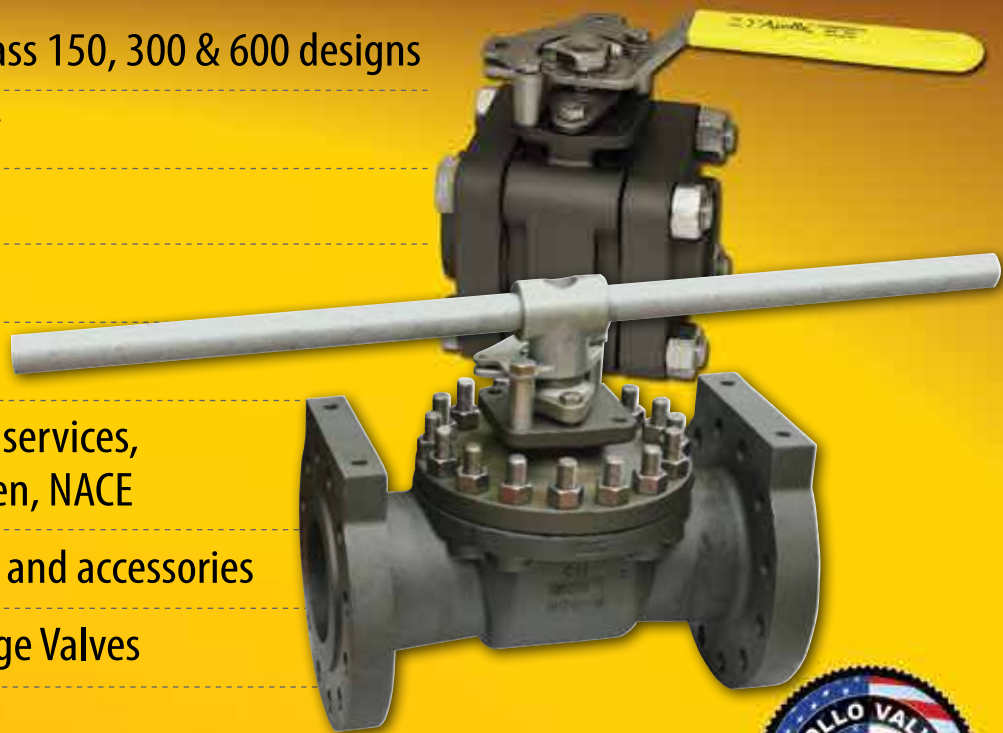

At our USA Foundries we cast:

- Carbon Steel & Low-Temp Carbon Steel
- Stainless Steel & Low Carbon Stainless Steels
- Alloy 20
- Duplex & Super Duplex
- Hastelloy®
- Monel®
- Nickel & Nickel-Copper Alloys
- Titanium

Apollo Industrial Ball Valves provide positive shut-off, and outstanding performance in an extensive range of industrial applications.

Top Entry **Inline Repairable** **Built to Last**

Available in ASME Class 150, 300 and 600, they're available configured to withstand temperatures from -150°F to 1000°F (-101°C to 538°C), and pressures from vacuum to 1500 psig (103 bar). Apollo top entry ball valves are offered in sizes 1/2" to 12" (DN 15 to DN 300). New to this line is the ISO 5211 mounting pad bonnet design.

It is easy to match an Apollo top entry ball valve to your specs. You can select from 15 body materials, 14 different seating materials in four seat designs, 14 ball material choices including ceramics, 7 end configurations, and 4 interchangeable bonnet styles, including extended bonnets.

Firesafe Compliant: When specified, Apollo top entry valves can be furnished with trim designs suitable for firesafe applications. For additional details visit www.apollovalves.com and request catalog TECA9000.

This design offers you improved flow rates and lower pressure drops. Their unique seven-degree wedge seat design compensates for wear or thermally induced dimensional changes, so you get a longer life out of every valve.

The wedge seat design also makes inspection and service easier. The Top Entry design is suitable for rebuilding inline, thus minimizing maintenance downtime. Potential leak paths are minimized by the one piece body design.



83B/86B Three-Piece Valves **ASME Class 600**

Apollo® full-port, three-piece ASME Class 600 ball valves are available in sizes from 1/4" to 2" (DN 8 to DN 50) with a wide range of trim packages and end configurations. Body materials include stainless steel, carbon steel and special corrosion resistant alloys. Every size is ASME Class 600 rated, unlike some other manufacturers' valves, which are de-rated in the larger sizes. The Apollo three-piece valve is a rugged heavy wall design, satisfying all of the requirements of ASME/ANSI - B16.34, B31.1 and B31.3.

Built for extended service and minimal maintenance, they're ideal for harsh plant environments where reliable operation is critical: pulp and paper, power generation, oil fields, refineries and chemical processing.

Apollo ASME Class 600 three-piece valves offer specifying engineers real advantages.

FEATURES:

- ☑ Swing-out center section for true in-line repairability
- ☑ Available in a variety of end connections; threaded, socket weld, butt weld
- ☑ Pressure-balanced solid ball
- ☑ Anti-blowout bottom entry stem design
- ☑ Antistatic ground ball and stem
- ☑ Lockable in open or closed position
- ☑ Fully machined ISO 5211 actuator mounting
- ☑ 250 psig (17 bar) saturated steam rating
- ☑ Vacuum service to 29" of Hg (737 mm Hg)
- ☑ Broad Range of Materials, Options, Configurations, and Actuation
- ☑ Cast, Machined, Assembled, and Tested in U.S.A.



87A/88A Flanged Valves

High Performance Features

Apollo 87A and 88A Series, ASME Class 150 and 300 flanged ball valves are available in stainless steel, carbon steel and specialty alloys in sizes from 1/2" to 12" (DN 15 to DN 300). They include as standard many features offered only as options on competitive valves.

When specified with the "-24" suffix, which includes a graphite gasket for the body seal and graphite multi-ring stem packing, Apollo flanged valves are certified firesafe to API 607 5th or 6th edition.



FEATURES:

- ✓ Regular and Full Port ASME designs
- ✓ Available in uni-body, and easy to repair split body designs
- ✓ Anti-static grounded ball and stem
- ✓ Locking device
- ✓ ISO 5211 mounting pad
- ✓ Vacuum service to 29" of Hg (737 mm Hg)
- ✓ 150 psig saturated steam rating (optional Class 300 configuration with 250 psig saturated steam rating)
- ✓ Broad Range of Materials, Options, Configurations, and Actuation
- ✓ Cast, Machined, Assembled, and Tested in U.S.A.

87AF/88AF Flanged Valves

ASME Class 600

Apollo® 87A-F, 88A-F, & 88L-F Series ASME Class 600 flange ball valves are available in stainless steel, carbon steel, and low temperature carbon steel in sizes 1" to 8" (DN25 to DN200). A broad range of specialty alloy materials, options, and configurations are also available.



Apollo® Industrial Ball Valves provide positive shut-off and outstanding performance in an extensive range of industrial applications.

FEATURES:

- ✓ Fully compliant to ASME B16.34 & API 608
- ✓ Two position locking device (valves 6" & smaller)
- ✓ Chevron style adjustable stem seals
- ✓ ISO 5211 mounting pad bolt pattern
- ✓ Slot vented ball for thermal expansion
- ✓ Anti-static grounded ball & stem
- ✓ Blow-out proof stem design
- ✓ Rated for 250 psig saturated steam (with appropriate seat/seal options)
- ✓ API 607 fire safe to 6th edition (with appropriate seat/seal options)
- ✓ Vacuum service to 29 inches of Hg (737 mm Hg)
- ✓ NACE MR0175 (2000) and MR0103 (2003) compliant
- ✓ Cast, machined, assembled, and tested in U.S.A.





Industrial Products Binder

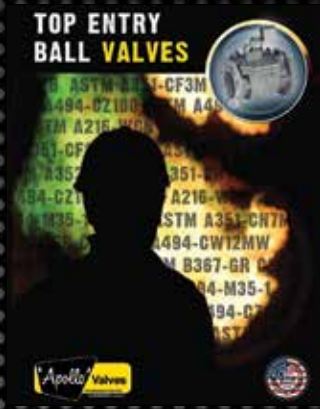

Top Entry Catalog

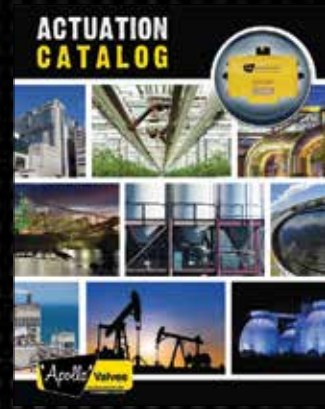

Actuation Catalog

Conbraco Industries, Inc. warrants, to its initial purchaser only, that its products which are delivered to this initial purchaser will be of the kind described in the order or price list and will be free of defects in workmanship or material for a period of FIVE years from the date of delivery to you, our initial purchaser. This warranty applies to Apollo brand product with "Made in the USA" markings only.

Should any failure to conform to this warranty appear within FIVE years after the date of the initial delivery to our initial purchaser, Conbraco will, upon written notification thereof and substantiation that the goods have been stored, installed, maintained and operated in accordance with Conbraco's recommendations and standard industry practice, correct such defects by suitable repair or replacement at Conbraco's own expense.

APOLLO INTERNATIONAL PRODUCTS: Conbraco Industries, Inc. warrants its International products, to its initial purchaser only, that its international products which are delivered to this initial purchaser will be of the kind described in the order or price list and will be free of defects in workmanship or material for a period of TWO years from the date of delivery to you, our initial purchaser.

THIS WARRANTY IS EXCLUSIVE AND IS IN LIEU OF ANY IMPLIED WARRANTY OF MERCHANTABILITY, FITNESS FOR A PARTICULAR PURPOSE OR OTHER WARRANTY OF QUALITY, WHETHER EXPRESSED OR IMPLIED, EXCEPT THE WARRANTY OF TITLE AND AGAINST PATENT INFRINGEMENT. Correction of non-conformities, in the manner and for the period of time provided above, shall constitute fulfillment of all liabilities of Conbraco to our initial purchaser, with respect to the goods, whether based on contract, negligence, strict tort or otherwise. It is the intention of Conbraco Industries, Inc. that no warranty of any kind, whether expressed or implied shall pass through our initial purchaser to any other person or corporation.

LIMITATION OF LIABILITY: Conbraco Industries, inc. SHALL NOT UNDER ANY CIRCUMSTANCES BE LIABLE FOR SPECIAL OR CONSEQUENTIAL DAMAGES SUCH AS, BUT NOT LIMITED TO, DAMAGES OR TO LOSS OF OTHER PROPERTY OR EQUIPMENT, LOSS OF PROFITS OR REVENUE, COST OF CAPITAL, COST OF PURCHASED OR REPLACEMENT GOODS, OR CLAIMS OF CUSTOMERS OF OUR INITIAL PURCHASER. THE REMEDIES OF OUR INITIAL PURCHASER, AND ALL OTHERS, SET FORTH HEREIN, ARE EXCLUSIVE, AND THE LIABILITY OF CONBRACO WITH RESPECT TO SAME SHALL NOT, EXCEPT AS EXPRESSLY PROVIDED HEREIN, EXCEED THE PRICE OF THE GOODS UPON WHICH SUCH LIABILITY IS BASED.

* It is the end user's responsibility to confirm that items intended for use satisfy local codes and standards.



For more information or to find your local rep, please contact our Customer Service department, or visit us on the web.

www.apollovalves.com

Phone: (704) 841-6000

Fax: (704) 841-6020

